

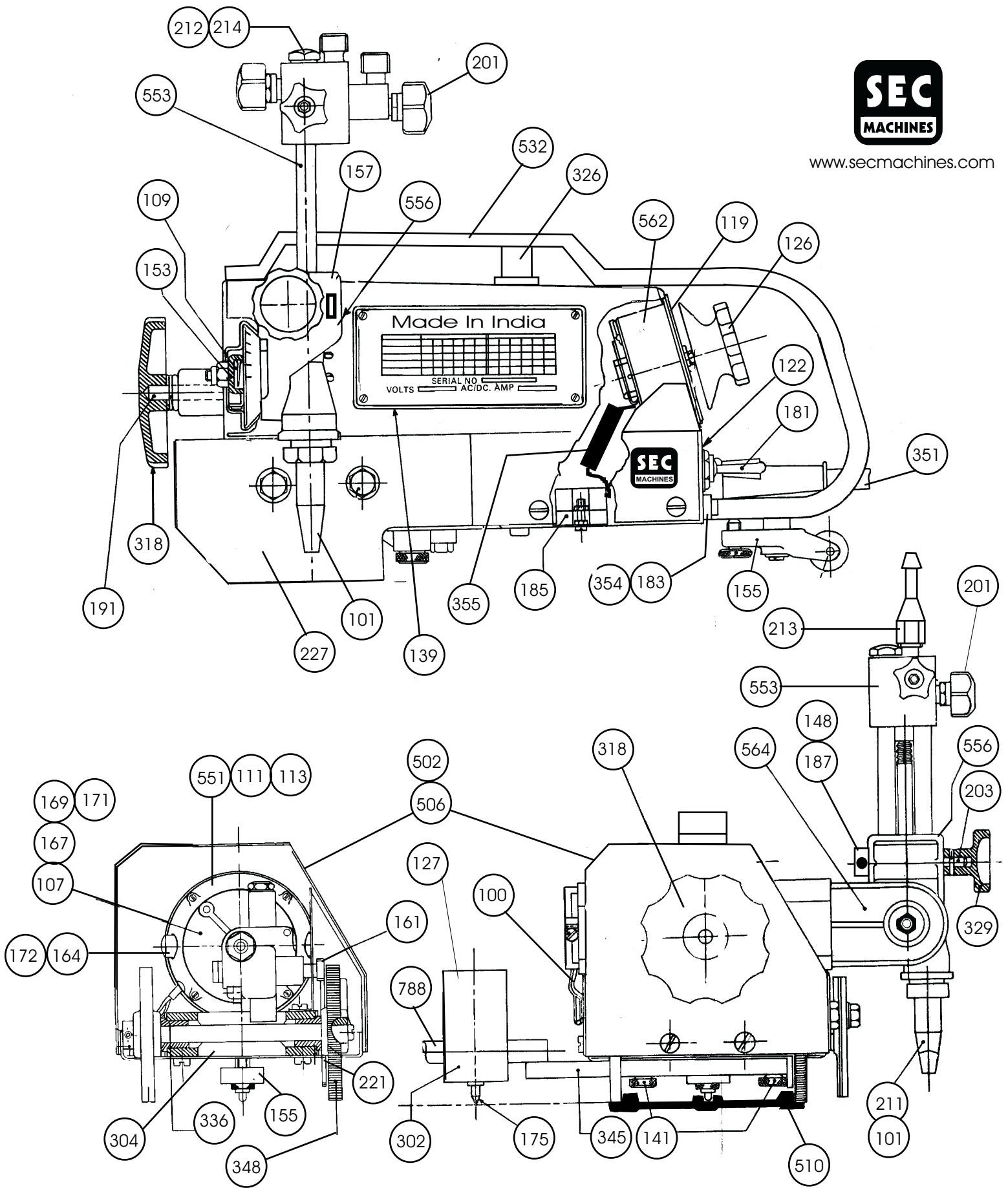

www.secmachines.com



Oxy 200 Spares' General Arrangement Drawing

Spare Parts Price List of Oxy 200 Machine

| Part No . | Description | Q ty . |
|------------------|-------------------------------|---------------|
| 100 | Hose clip set | 1 Set |
| 101 | Nozzle | 1 Pc |
| 107 | Gearbox - Unit | 1 Set |
| 109 | Spring Big | 1 Pc |
| 111 | Field Coil | 1 Pc |
| 113 | Armature | 1 Pc |
| 119 | Regulator Label | 1 Pc |
| 122 | FOR Label | 1 Pc |
| 126 | Disk Knob | 1 Pc |
| 127 | Circle Cutting Attachment | 1 Pc |
| 139 | Label Oxy1 - Main | 1 Pc |
| 141 | L Plate Bolts | 1 Set |
| 148 | Gutka | 1 Pc |
| 153 | Spring Cap | 1 Pc |
| 155 | Swivel wheel assembly | 1 Set |
| 157 | Strip | 1 Pc |
| 161 | Output Gear - Motor | 1 Pc |
| 164 | Carbon Brush Set | 1 Set |
| 167 | Double Start Worm | 1 Pc |
| 169 | Brass Gear - Gear Box | 1 Pc |
| 171 | Fibre Gear - Gear Box | 1 Pc |
| 172 | Carbon Holder With Cap | 1 Set |
| 175 | Pointer | 1 Pc |
| 181 | Centre Off Switch | 1 Pc |
| 183 | Fuse Holder | 1 Pc |
| 185 | Connector - Small | 1 Pc |
| 187 | Spring Small | 1 Pc |
| 191 | Handwheel Pinion - small | 1 Set |
| 201 | Cutter Knobs - Small | 3 Pcs |
| 203 | Brass Pinion - Torch Holder | 1 Pc |
| 211 | Head Nut - Small | 1 Pc |
| 212 | Injector Nut | 1 Pc |
| 213 | Non Return Valves - 1/4 | 2 Pcs |
| 214 | Injector | 1 Pc |
| 221 | Wheel Gear | 1 Pc |
| 227 | Heat Shield Sandwich | 1 Set |
| 302 | Weight - Circle Cutting | 1 Pc |
| 304 | Chasis Small | 1 Pc |
| 318 | Handwheel Knob | 1 Pc |
| 326 | Handle Collar | 1 Pc |
| 329 | Torch Holder knob - Small | 1 Pc |
| 336 | Chasis Bushes - Small | 1 Set |
| 345 | L Plate | 1 Pc |
| 348 | Wheel Set - Small | 1 Set |
| 351 | Cable - 4 Mtr | 4 Mtrs |
| 354 | Fuse 0.5 | 1 Pc |
| 355 | Resistor 10W | 1 Pc |
| 506 | Tin Body -Oxy 150 | 1 Set |
| 510 | Aluminium Railing | 1 Pc |
| 532 | Handle - Oxy 1 | 1 Pc |
| 551 | Motor | 1 Set |
| 553 | Cutting Torch - Small Oxy 150 | 1 Pc |
| 556 | Torch Holder Unit | 1 Set |
| 562 | Regulator - Oxy 1 | 1 Pc |
| 564 | Sliding Zinc Plate | 1 Pc |
| 788 | MS Rod - Circle Cutting | 1 Pc |